

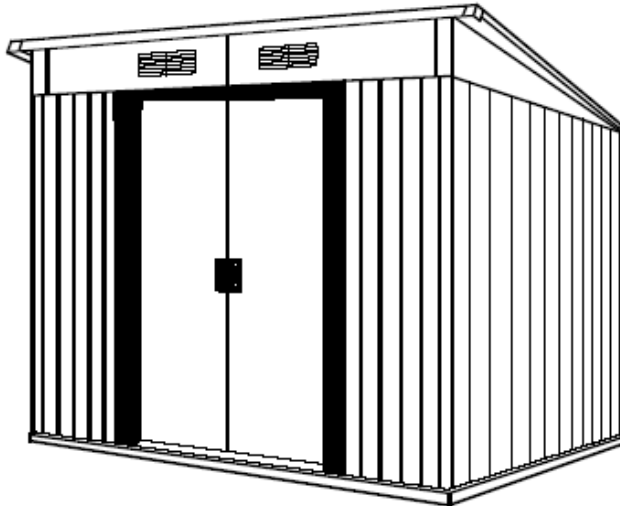

Pent Roof Type Metal Garden Shed

OWNER'S MANUAL / Instructions for Assembly Size 8' x 4'

Ver: 1.0



**Customer
Service Hotline
(800) 483-4674**
www.uspolymersinc.com

Requires two people and takes 2-3 hours for Installation.

- Tall Walk in Shed
- Quick & Easy Assembly
- Ridge Reinforced Walls
- Wide Double Doors
- Available in Various Sizes

Call us for any missing or damaged parts.
Do not return to the store.

Duramax Storage Shed Limited Fifteen Year Warranty

U.S. Polymer Inc. will send a replacement part free of charge, in the event of material defects and or workmanship for a period of fifteen years from the date of purchase.

This warranty is extended only to the original purchaser. A purchase receipt or other proof of date of original purchase will be required before warranty service is rendered. In no event shall we pay the cost of flooring, labor, installation or any other costs related thereto.

This warranty only covers failures due to defects in material or workmanship which occurs during normal use and does not extend to color change arising due to normal weathering or to damage resulting from misuse or neglect, commercial use, failure to follow assembly instructions and the owner's manual (including proper anchoring of the shed), painting, forces of nature and other causes which is beyond our control.

Claims under this warranty must be made within the warranty period by calling 1-800-483-4674 or mail in a dated sales slip and clear photograph of the part to:

U.S. Polymers, Inc.
6915 Slauson Avenue
Commerce, CA 90040

We reserve the right to discontinue or change components. If a component has been discontinued or is not available, U.S. Polymers, Inc. reserves the right to substitute a component of equal quality as may be compatible.

Limits and Exclusions

There are no express warranties except as listed above. The warrantor shall not be liable for incidental or consequential damages resulting from the use of this product, or arising out of any breach of this warranty. All express warranties are limited to the warranty period set forth above. Some states do not allow the exclusion or limitation on how long an implied warranty lasts, so the above limitations may not apply to you.

This warranty gives you specific legal rights and you may also have other rights which vary from state to state or country to country.

IMPORTANT: USE HAND GLOVES TO PREVENT INJURY.

Parts List

Note: Check all parts prior to installation.

CODE	DESCRIPTION	QTY
BLB	BASE BAR BACK LEFT	1
BRB	BASE BAR BACK RIGHT	1
BSC	BASE BAR SIDE LEFT & RIGHT	2
BBF	BASE BAR FRONT LEFT & RIGHT	2
ECB	ENTRANCE TAPER CHANNEL	1
DCL	DOOR COLUMN PROFILE LEFT	1
DCR	DOOR COLUMN PROFILE RIGHT	1
ABBLR	TOP ANGLE BACK LEFT & RIGHT	2
ASLR	TOP ANGLE SIDE LEFT & RIGHT	2
SCB	SLIDING CHANNEL COVER	1
SSB	SLIDING CHANNEL SUPPORT	1
SLB	SLIDING CHANNEL LEFT	1
SRB	SLIDING CHANNEL RIGHT	1
RSLR	ROOF SUPPORT LEFT & RIGHT	2
RSM	ROOF SUPPORT MIDDLE	1
SBSLR	SUPPORT BRACKET SIDE LEFT & RIGHT	3
GPSLR	GABLE PANEL SUPPORT SIDE LEFT & RIGHT	4
GPCLR	GABLE PANEL SUPPORT CENTER LEFT & RIGHT	4
RFRB	ROOF FLASHING (FRONT RIGHT / BACK LEFT)	2
RFLB	ROOF FLASHING (FRONT LEFT / BACK RIGHT)	2
RFLSR	ROOF FLASHING SIDE LEFT & RIGHT	2
TSLB	DOOR PANEL STRIP TOP LEFT	1
TSRB	DOOR PANEL STRIP TOP RIGHT	1
BSLB	DOOR PANEL STRIP BOTTOM LEFT	1
BSRB	DOOR PANEL STRIP BOTTOM RIGHT	1
DSS	DOOR PANEL STRIP SIDE LEFT & RIGHT	2
DSCB	DOOR PANEL STRIP CROSS	4
WCF	WALL PANEL CORNER FRONT LEFT & RIGHT	2
WCB	WALL PANEL CORNER BACK LEFT & RIGHT	2
WS	WALL PANEL SIDE	4
WFL	WALL PANEL FRONT LEFT	1
WFR	WALL PANEL FRONT RIGHT	1
GPSL	GABLE PANEL SIDE LEFT	1
GPSR	GABLE PANEL SIDE RIGHT	1
FB1B	FASCIA BOARD FRONT LEFT	1
FB2B	FASCIA BOARD FRONT RIGHT	1
RPSLR	ROOF PANEL SIDE LEFT & RIGHT	2
RPCLR	ROOF PANEL CENTER LEFT & RIGHT	3
DPLB	DOOR PANEL LEFT	1
DPRB	DOOR PANEL RIGHT	1

Tools You Will Need

Hand Gloves	8' Step Ladder
Cordless Drill - Philips Head	Adjustable pliers
Screw driver - Philips Head	Level - 3ft.
Carpenters Square	Tape Measure
Eye Protector	

ACCESSORIES

CODE	DESCRIPTION	QTY
BS	BOTTOM SLIDER	4
DH	DOOR HANDLE	2
TC	TOP CORNER	4
TS	TOP SLIDER	4
VC	VENTILATION COVER	2
PW	PLASTIC WASHER	3 slabs
PC	PLASTIC SCREW COVER	3 slabs
S1	DIA. 4.2 x 10mm. (5/32" x 3/8")	
	SHEET METAL SCREW	168
S2	DIA. 4.2 x 16mm. (5/32" x 5/8")	
	SHEET METAL SCREW	26
S3	M4 x 16mm. (5/32" x 5/8")	
	MACHINE SCREW W/ NUT	83

PROFILES

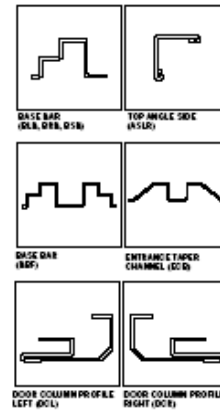

ACCESSORIES

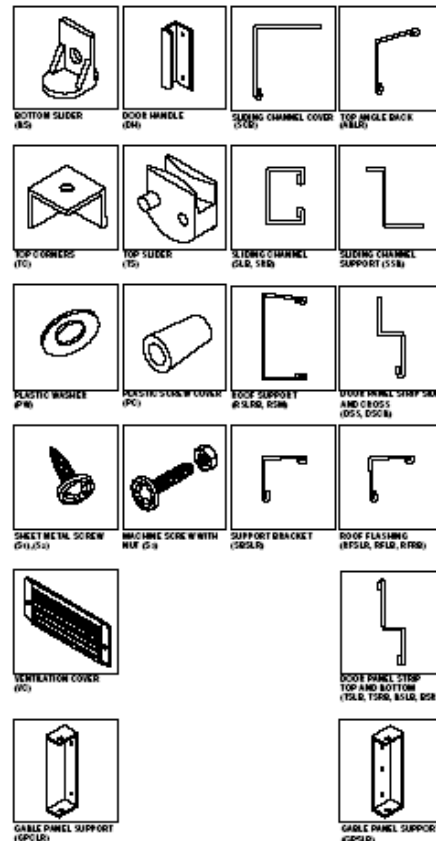

IMPORTANT: USE HAND GLOVES TO PREVENT INJURY.

Exploded View

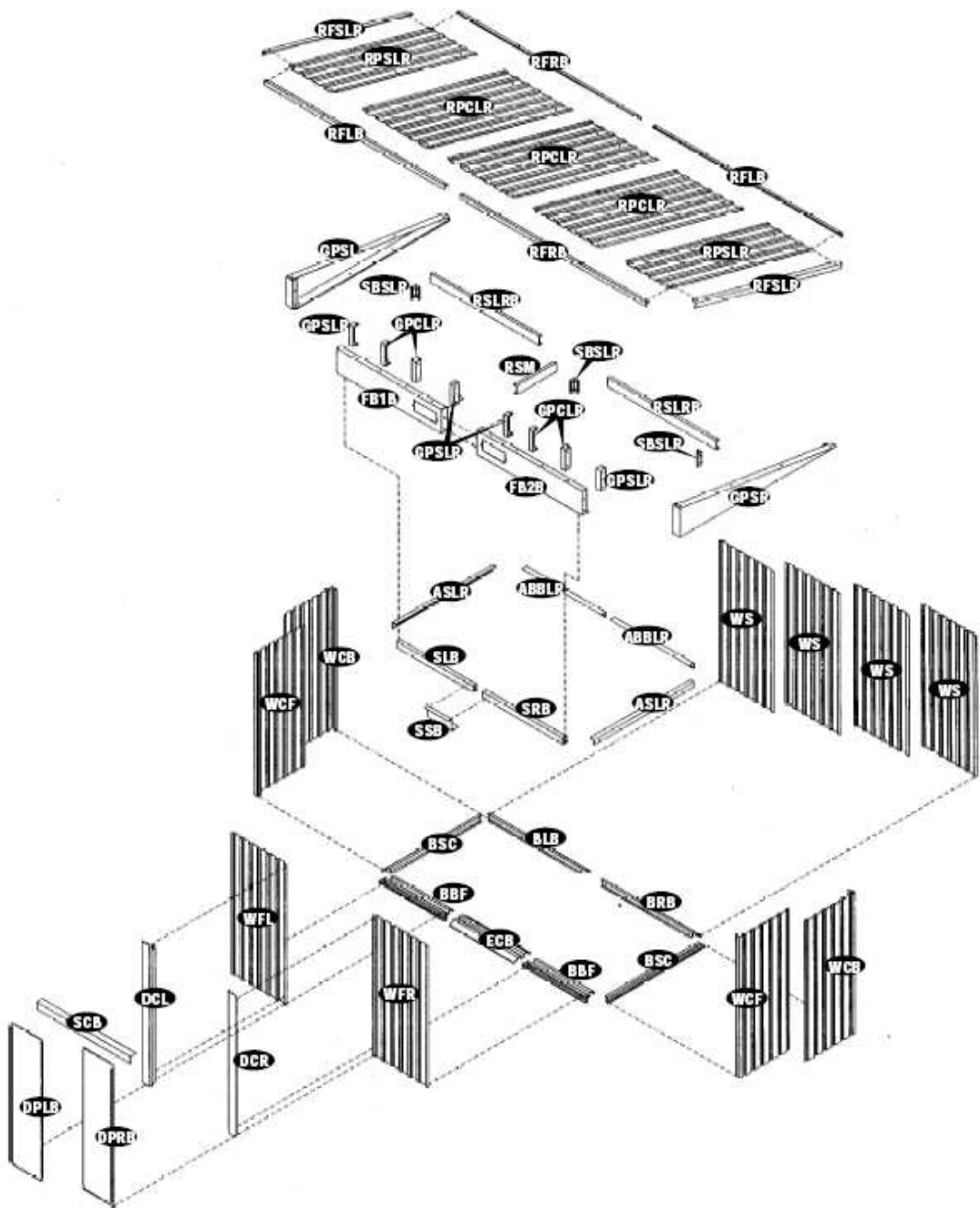

IMPORTANT: USE HAND GLOVES TO PREVENT INJURY.

A. Foundation & Base Frame

Note: It is important that these instructions are followed step by step.

DuraMax must be installed on a level wooden platform or a level concrete foundation.



Wooden platform is extra and is not included. Don't install under windy conditions.

Parts needed:

- | | |
|---------------------------------|--------------|
| (1) Base bar back left | (BLB) |
| (1) Base bar back right | (BRB) |
| (2) Base bar side left & right | (BSC) |
| (2) Base bar front left & right | (BBF) |
| (1) Entrance taper channel | (ECB) |
| (12) Sheet metal screws | (S1) |
| (22) Sheet metal screws | (S2) |

1. Use pressure treated wood studs 2"x 4" (50mm x 88.9mm) to create a platform frame that has an outside dimension of 47" x 102" (1193.80mm x 2590.80mm).

2. Using exterior grade CDX 3/4" (19mm) plywood, cut the sheets to form solid foundation as shown. Foundation must be square and level.

Wooden Platform (Not Included)

The following are the list of lumber and sizes you will need.

Pressure Treated - Wood Studs:

- 3ea 2" x 4" x 91 1/2" (50mm x 88.9mm x 2324.1mm)
- 3ea 2" x 4" x 47" (50mm x 88.9mm x 1193.8mm)

Exterior Grade (CDX) - 3/4" (19mm) plywood

- 1ea 3/4" x 47" x 96" (19mm x 1193.8mm x 2440mm)
- 1ea 3/4" x 6' x 47" (19mm x 152.4mm x 1193.8mm)

L-Brackets: 4ea

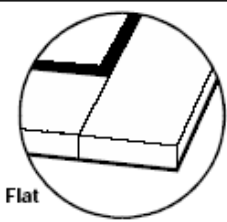

Lay 50mm x 88.9mm Flat

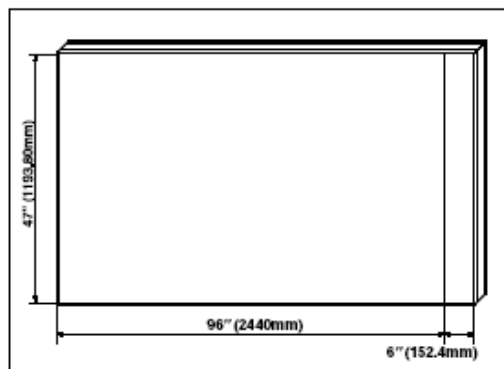
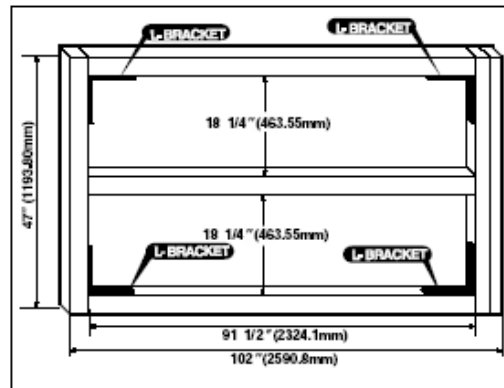

1

IMPORTANT: USE HAND GLOVES TO PREVENT INJURY.

3. Assemble base bar back left (BLB) and base bar back right (BRB) with four (S1) screws. See fig. 1 & 2.

Note Take care of sharp edges.

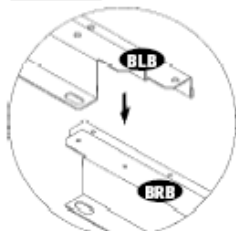

Fig.1

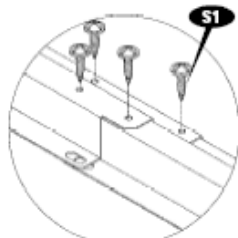
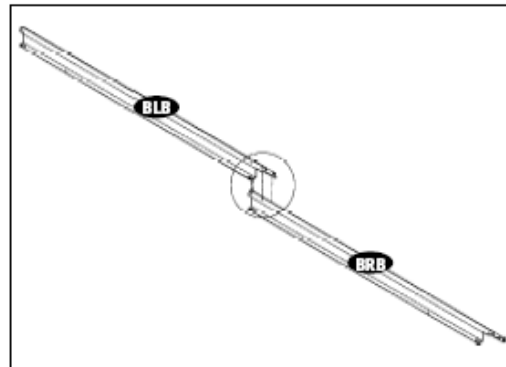
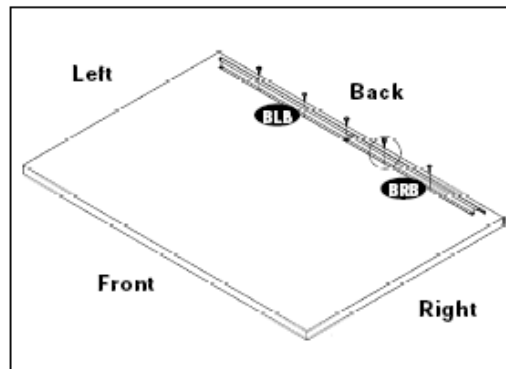

Fig.2



4. Place the base bar assembly on top of the foundation. Use (S2) screws to fix the assembly to foundation.



5. Insert the base bar side (BSC) into (BLB) & (BRB) secure with two (S1) screws on both sides. See blowup.

Step 1

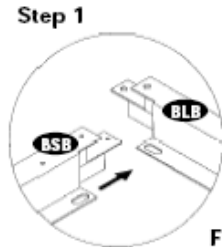
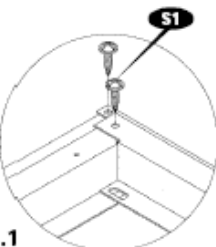

Fig.1



Step 2

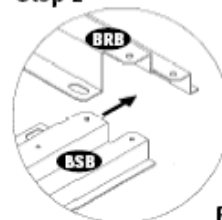
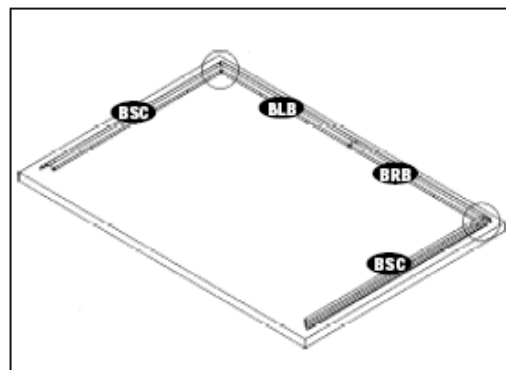
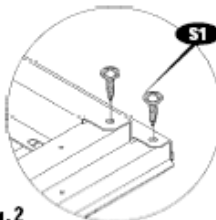

Fig.2



2

IMPORTANT. USE HAND GLOVES TO PREVENT INJURY

6. Using a carpenter square, line up the corners. Secure the base (BSC) to the foundation with (S2) screws. See blowup.

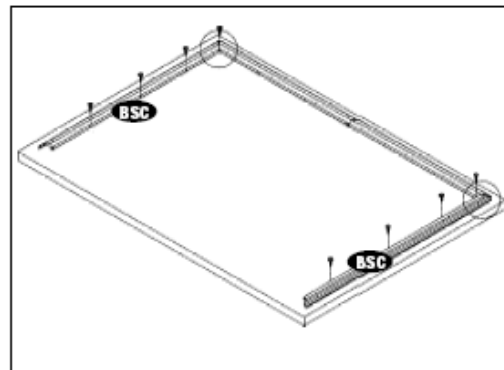
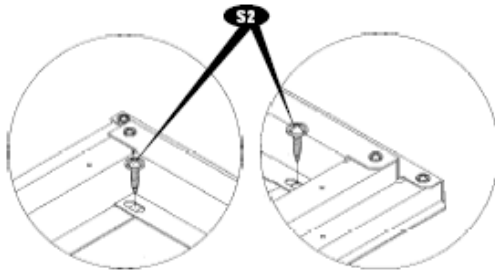

7. Place the base bar (BBF) on top of (BSC) on both sides. Secure with (S1) screw to (BSC) on both corners. See fig. 1 & 2.

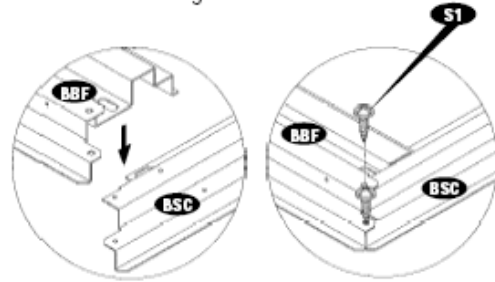
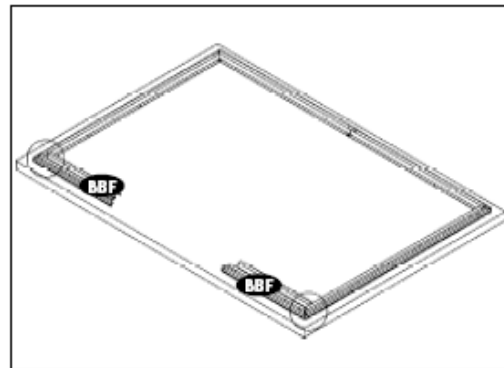
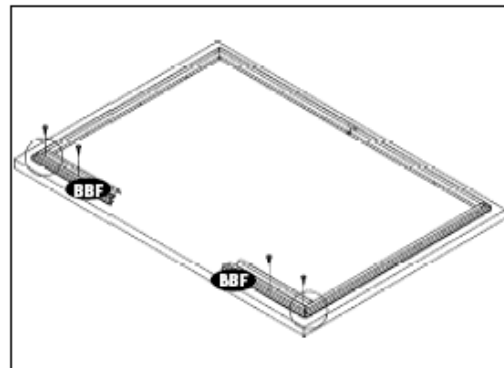
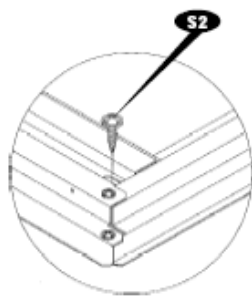

Fig.1

Fig.2



8. Using the carpenter square, line up the corners. Secure the base (BBF) to the foundation with (S2) screws.



3

IMPORTANT: USE HAND GLOVES TO PREVENT INJURY.

9. Place the entrance taper channel (ECB) on top of the (BBF). Secure with (S2) screws to the foundation. See fig. 1 & 2.

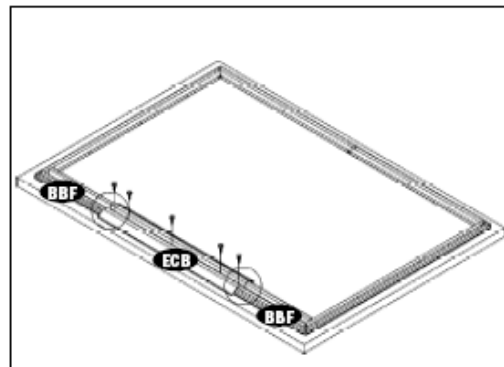
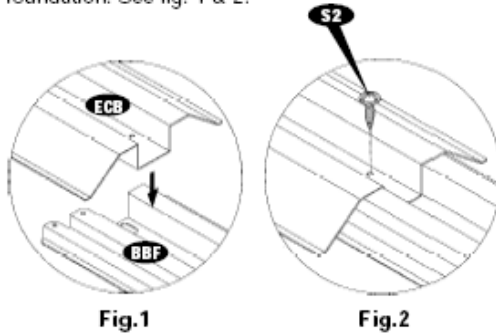

10. Measure in all direction as shown in figure. Make the base bar assembly in a perfect square.

Concrete foundation

10a. (Concrete foundation) Using a carpenter's square, line up corners. Align Base bars, mark the concrete at the holes in the base and drill concrete with 1/4" (dia. 6mm) concrete bit to accept anchor bolts with a 1 3/4" (44mm) depth. Replace base and secure with 1/4" x 1 3/8" (M6 x 35mm) anchor bolts (not provided).

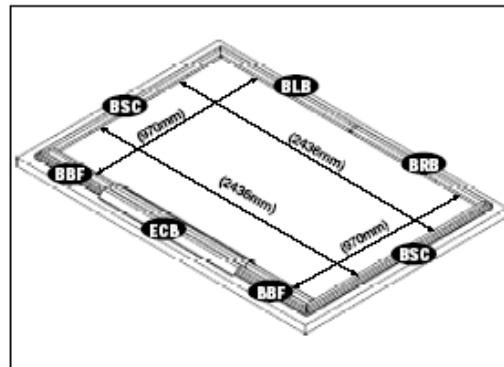

B. Walls & Columns



Note All panels are clearly marked and care should be taken to use the correct one.

Parts Needed:

(1) Wall panel front right	(WFR)	(2) Top angle side Left & Right	(ASLR)
(1) Wall panel front left	(WFL)	(1) Sliding channel support	(SSB)
(2) Wall panel corner front left & right	(WCF)	(1) Sliding channel cover	(SCB)
(2) Wall panel corner back left & right	(WCB)	(4) Top slider	(TS)
(4) Wall panel side	(WS)	(1) Door column profile left	(DCL)
(1) Sliding channel right	(SRB)	(1) Door column profile right	(DCR)
(1) Sliding channel left	(SLB)	(2) Top angle back left & right	(ABBLR)
		(71) Plastic washer	(PW)
		(78) Sheet metal screw	(S1)
		(9) Machine screw	(S3)

IMPORTANT: USE HAND GLOVES TO PREVENT INJURY.

1. Place the wall panel (WFR) on the base bar (BBF). Front right side of the shed line up the holes with base bar. Secure with (S1) screws with washers from outside.

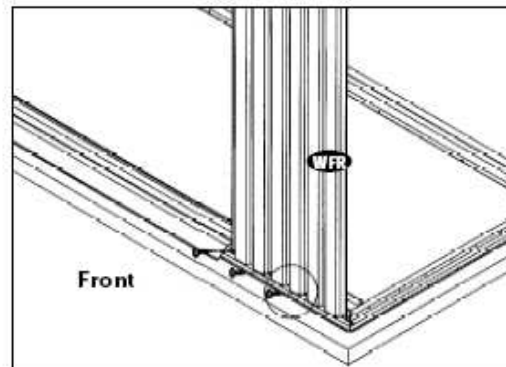
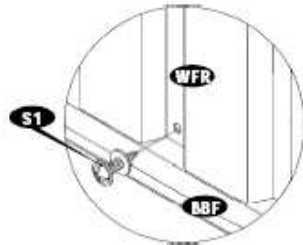

2. Place the wall panel corner front (WCF) on the base bar (BSC). Line up the holes with base bar and use (S1) screws with washers to secure.



Note Make sure the overlapping position is as shown in fig.1

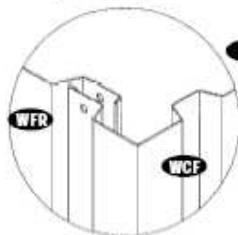

Fig.1

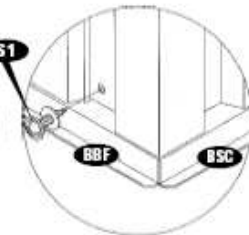
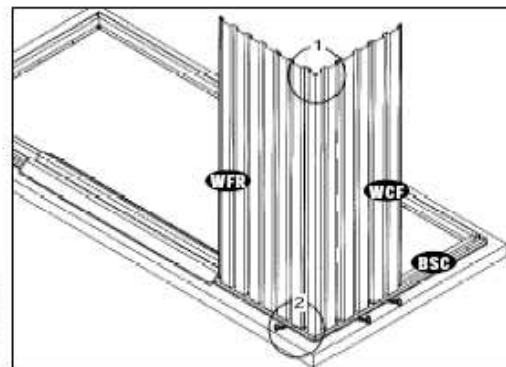
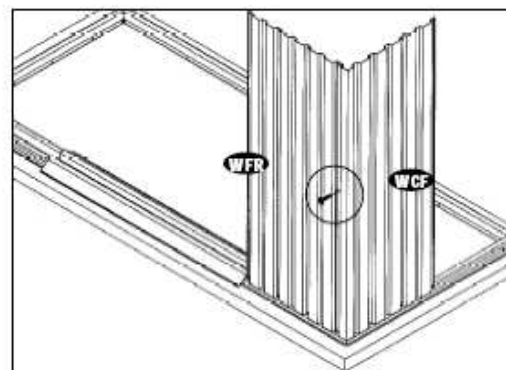
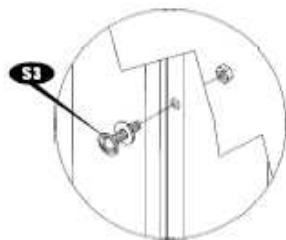

Fig.2



3. Use (S3) bolt and nut with washers to join together the wall panels.



4. Place the sliding channel right (SRB) on top of the wall panel (WFR) from inside. See the position in fig.1. Line up the holes with wall panel. Use (S1) screws with washers to fix. See fig.2

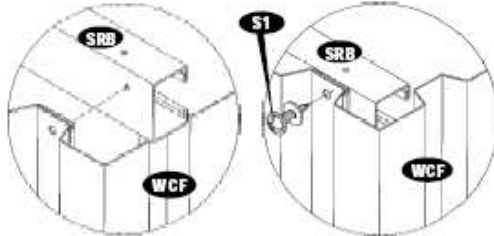
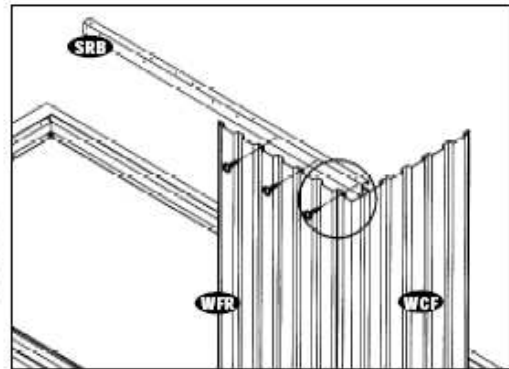

Fig.1

Fig.2



5. Insert the 2 pieces of (TS) Top slider into the sliding channel. See blowup.



Note Make sure the position of the projection on (TS) towards inside.

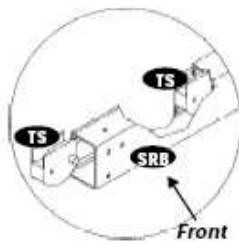

Front

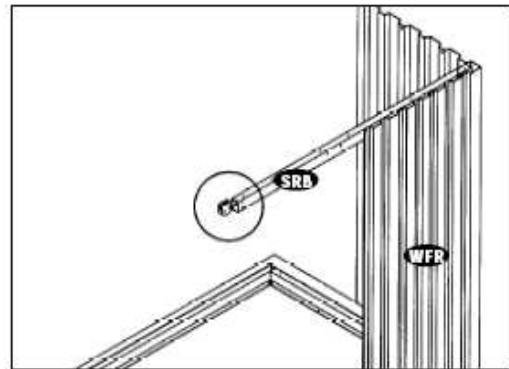

6. Place the wall panel (WFL) on the base bar (BBF). Front left side of the shed. Line up to holes with base bar. Secure with (S1) screws with washers from outside.

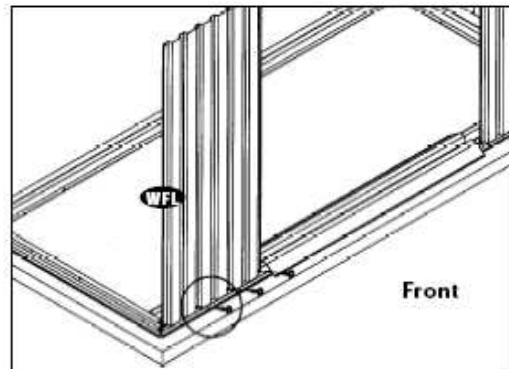
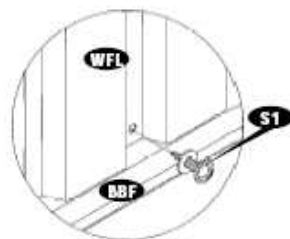

Front

7. Place the wall panel corner front (WCF) on the base bar (BSC). Line up the holes with base bar and use (S1) screws with washers to secure.

Note *Make sure the overlapping position is as shown in fig.1*

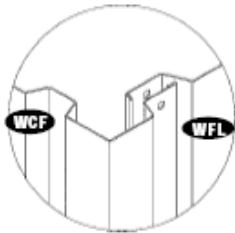

Fig.1

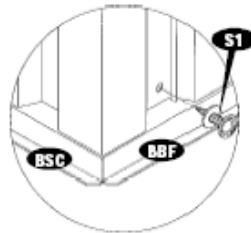
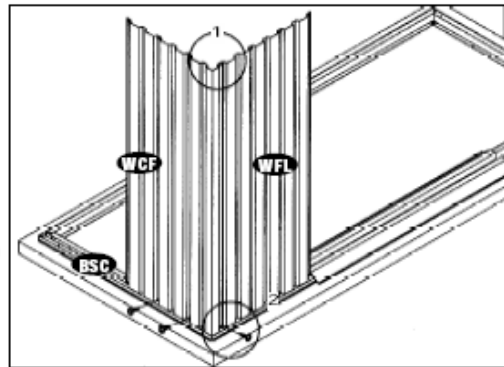
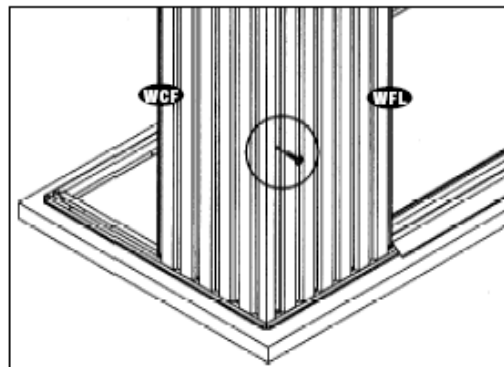
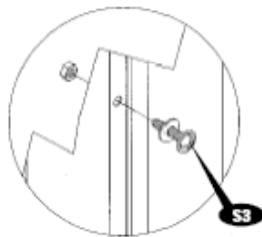

Fig.2



8. Use (S3) bolt and nut with washer to join together the wall panels.



9. Place the sliding channel left (SLB) on top of the wall panel (WFL) from inside. See the position in fig.1. Line up the holes with wall panel use (S1) screws with washers to fix. See fig. 2

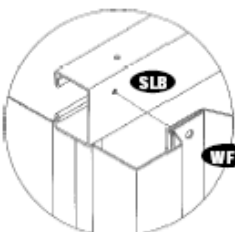

Fig.1

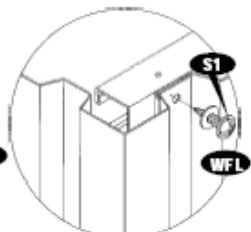
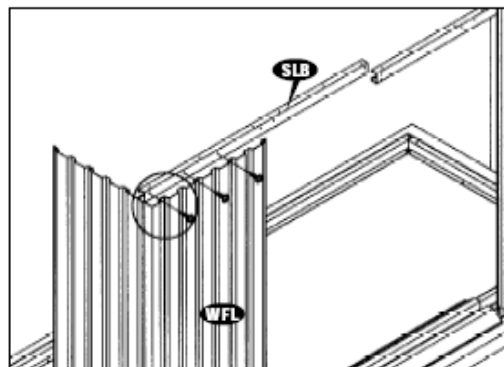

Fig.2



7

IMPORTANT: USE HAND GLOVES TO PREVENT INJURY.

10. Insert the 2 pieces of (TS) Top slider into the sliding channel. See blowup.

Note *Make sure the position of the projection on top slider towards inside.*

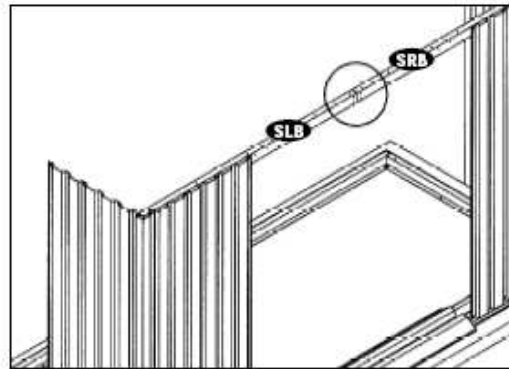
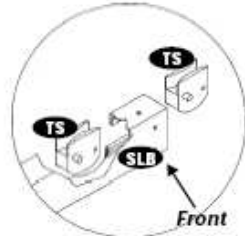

11. Place the sliding channel support (SSB) on the sliding channel (SLB) & (SRB). See fig.1. Align the holes with sliding channels and secure with (S1) screws. See fig. 2.

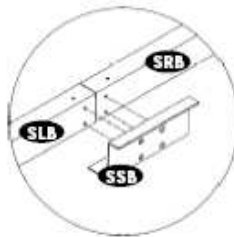

Fig.1

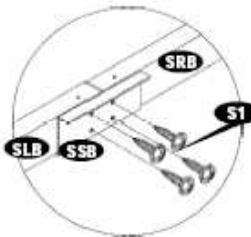
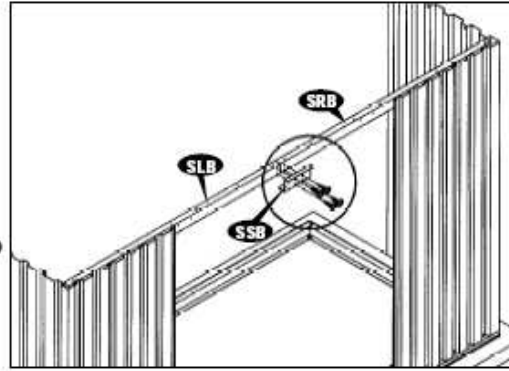
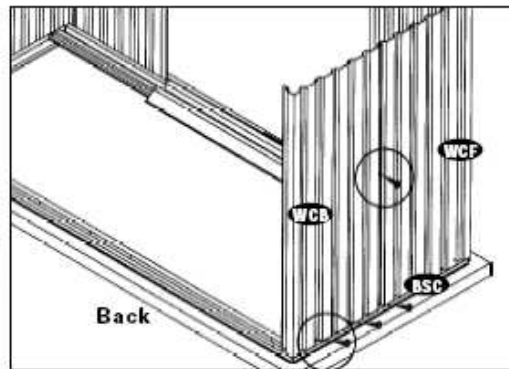
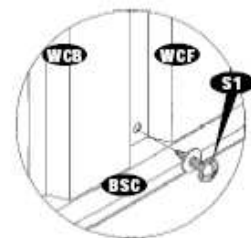
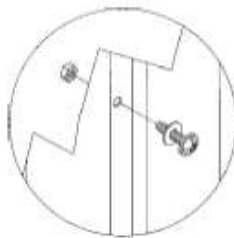

Fig.2



12. Place the wall panel corner back (WCB) on the base bar (BSC) and overlap to wall panel (WCF). Line up the wholes with base bar and use (S1) screws with washers to secure. Use (S3) bolt and nut with washer to join together in the middle of the wall panel.



8

IMPORTANT: USE HAND GLOVES TO PREVENT INJURY.

13. Place the wall panel (WS) on the base bar (BLB). Line up the holes with base bar. Secure with (S1) screws with washers. Use (S3) bolt and nut with washer to join together in the middle of the wall panel. See fig.1.

Note *Make sure the overlapping position is as shown in fig.2.*

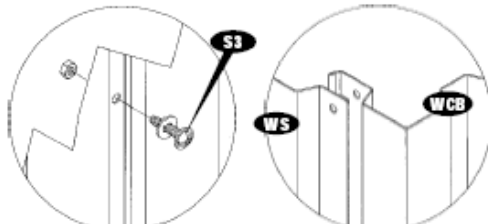
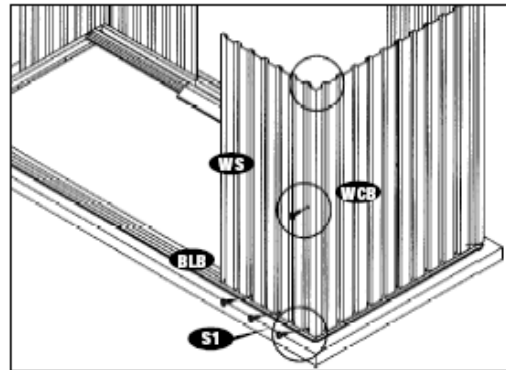

Fig.1

Fig.2



14. Place the top angle back left (ABBLR) on top of the wall panel (WS) from inside. See the position in fig.1. Line up holes with wall panel. Use (S1) screws with washers to fix. See fig. 2

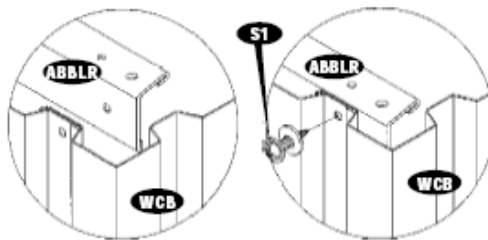
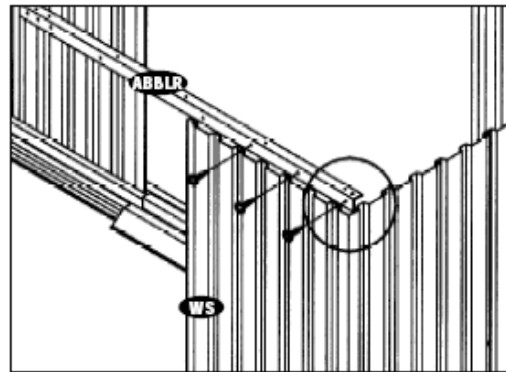

Fig.1

Fig.2



15. Place the top angle side (ASLR) on top of the wall panels (WCB) & (WCF). Line up the holes and secure with (S1) screws with washers. See fig.1 & 2.

Note *Top angle (ABBLR) must sit on top angle (ASLR).*

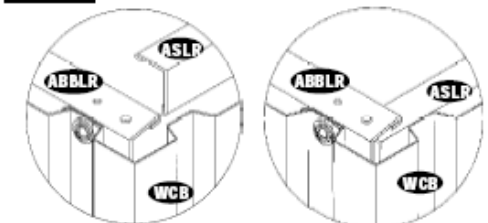
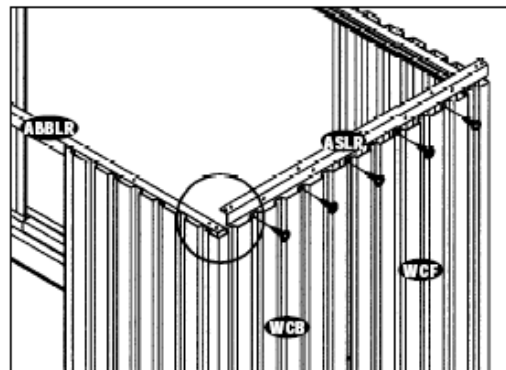
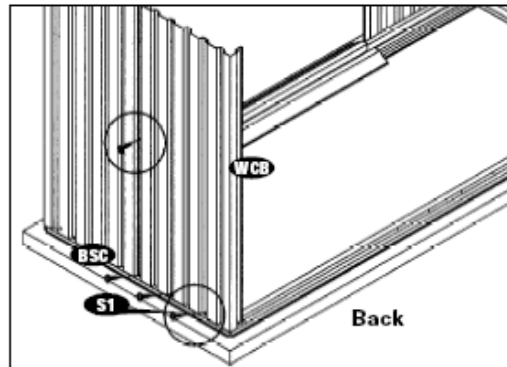
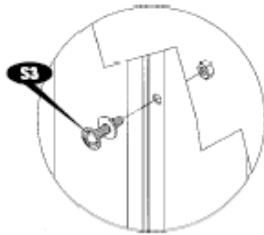

Fig.1

Fig.2



16. Place the wall panel corner back (WCB) on the base bar (BSC). Line up the holes with base bar and use (S1) screws with washers to secure. Use (S3) bolt and nut with washer to join together in the middle of the wall panel.



17. Place the wall panel (WS) on the base bar (BRB). Line up the holes with base bar and use (S1) screws with washers to secure. Use (S3) bolt and nut with washer to join together in the middle of the wall panel. See fig. 2.



Note Make sure the overlapping position of panels is as shown in fig. 1.

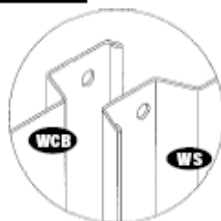

Fig.1

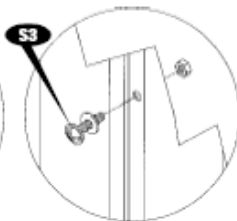
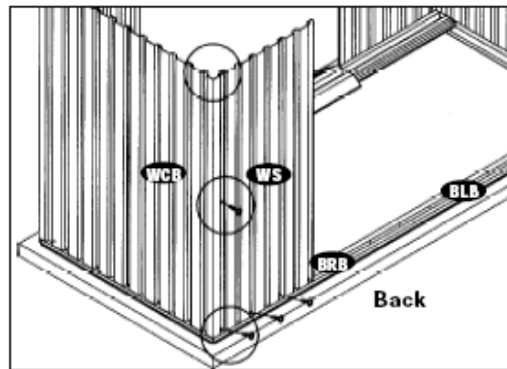

Fig.2



18. Place the top angle back right (ABBLR) on top of the wall panel (WS) from inside. See the position in fig.1. Line up the holes with wall panel use (S1) screws with washers to secure. See fig. 2

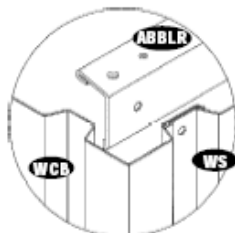

Fig.1

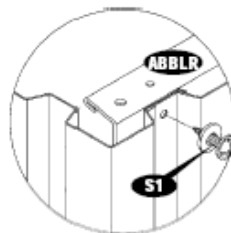
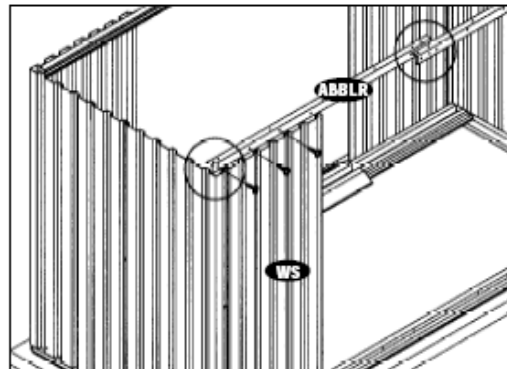
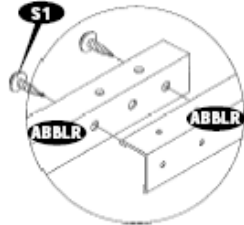

Fig.2



19. Join top angle back left & right (ABBLR) together with (S1) screws. See blown up.



20. Place the top angle side (ASLR) on top of the wall panels (WCF) & (WCB) from inside. Line up the holes with panels and secure with (S1) screws with washers.



Note Top angle (ABBLR) must sit on top angle (ASLR)



Fig.1

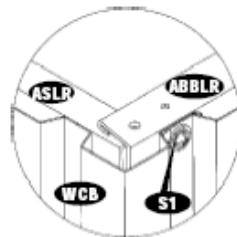
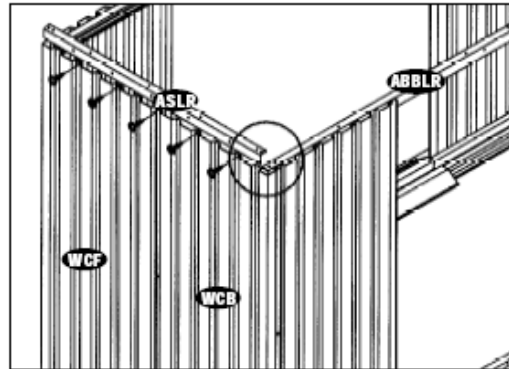

Fig.2



21. Place the wall panel (WS) on the base bar and secure with (S1) screws with washers to base bar & top angle. Use (S3) bolt and nut with washer to join together in middle of the wall panel. See fig. 2.



Note Make sure the overlapping position. See fig.1.

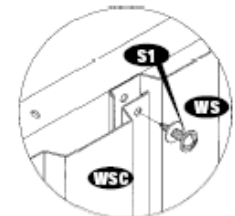
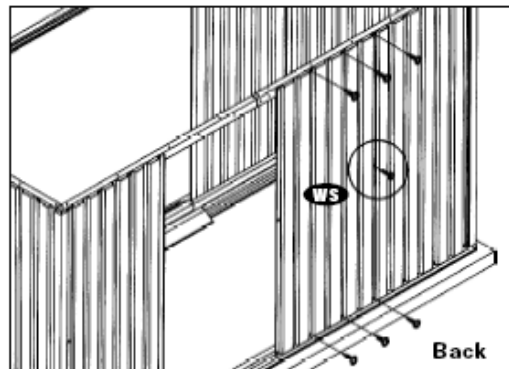

Fig.1



Fig.2



22. Follow the same step as item no. 21.

Note *Make sure the overlapping position. See fig.1.*

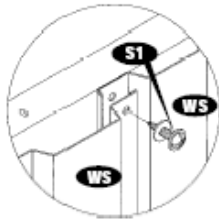

Fig.1

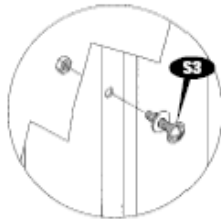
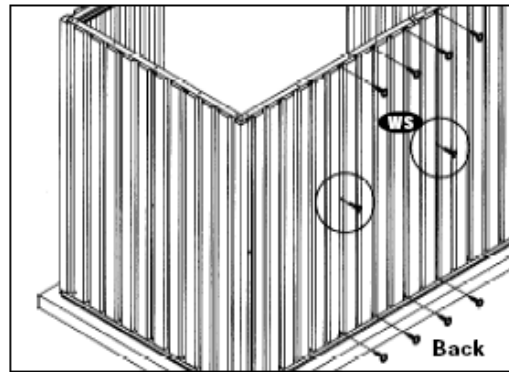

Fig.2



23. Place the left door column (DCL) on top of the base bar (BBF) and insert into the wall panel. See Blowup.

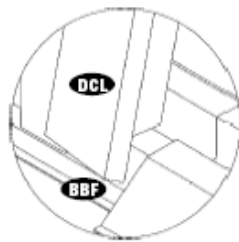

Fig.1

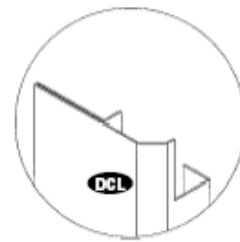
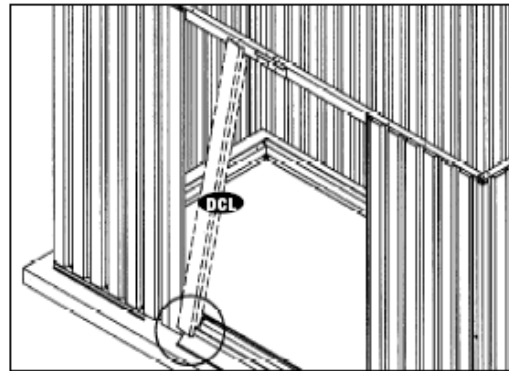
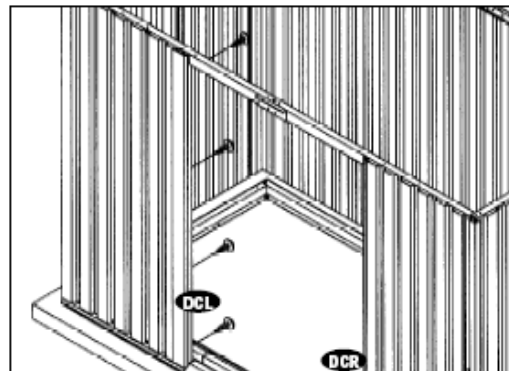
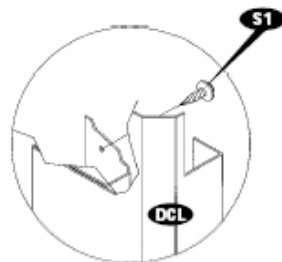

Fig.2



24. Secure the door column with (S1) screws. Repeat the same for the right door column (DCR).



25. Place the sliding channel cover (SCB) on top of the sliding channel (SLB & SRB). Secure with two (S1) screws. See blowup.

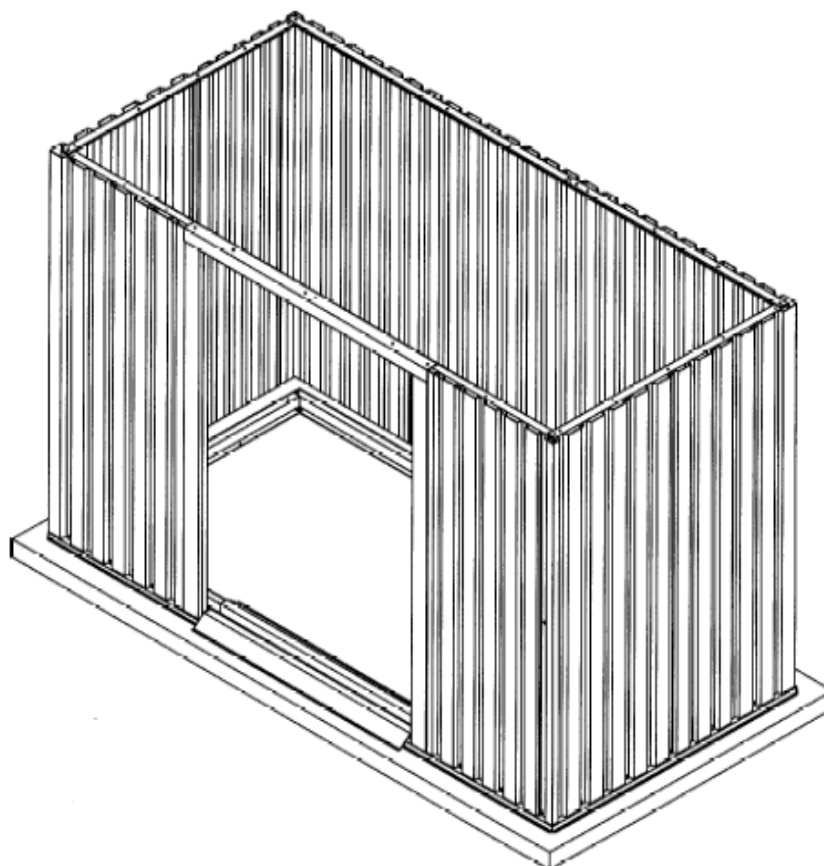
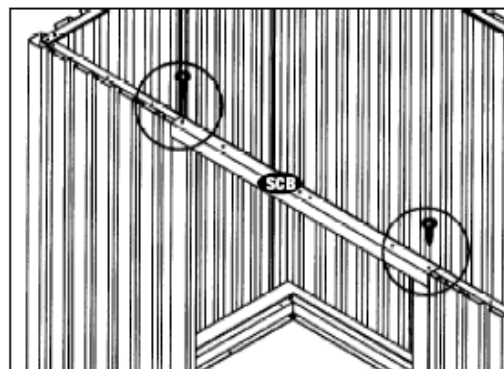
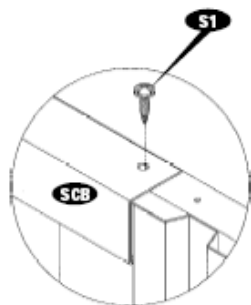

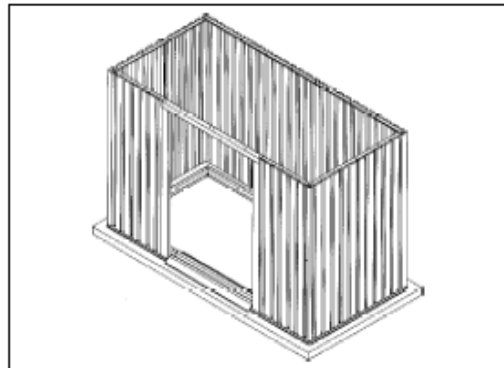

C. Roof

Note All parts are clearly marked and care should be taken to use the correct one.

Note Remove the Polyethylene Film before assembling.

Parts Needed:

(1) Fascia Board left	(FB1B)	(2) Roof Flashing front left / back right	(RFLB)
(1) Fascia Board right	(FB2B)	(2) Roof Flashing front right / back left	(RFRB)
(1) Gable Panel side left	(GPSL)	(2) Ventilation cover	(VC)
(1) Gable Panel side right	(GPSR)	(4) Top corners	(TC)
(2) Roof Support left / right	(RSLRB)	(73) Plastic washers	(PW)
(1) Roof Support middle	(RSM)	(64) Sheet metal screw	(S1)
(3) Support Bracket side left / right	(SBSLR)	(4) Sheet metal screw	(S2)
(4) Gable Panel support side left / right	(GPSLR)	(48) Machine screw with nut	(S3)
(4) Gable Panel support center left / right	(GPCLR)		
(2) Roof Panel side left / right	(RPSLR)		
(3) Roof Panel center left / right	(RPCLR)		
(2) Roof Flashing side left / right	(RFSLR)		

1. Assemble Fascia board (FB1B & FB2B) with center support (GPCLR). Align all matching holes and secure with (S3) bolt and nut with plastic washers (PW). See figure.

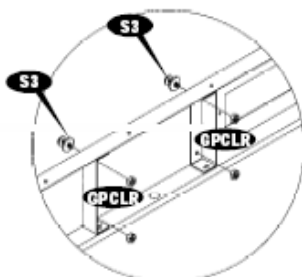
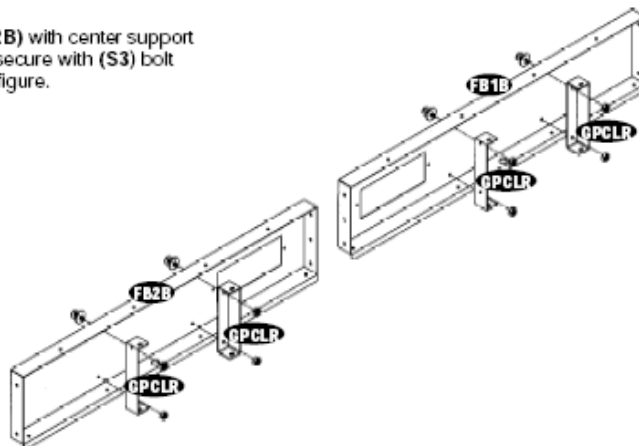

Fig.1



2. Place assembled Fascia board (FB2B) on top of the sliding channel (SRB). Align the holes with sliding channel and secure with (S1) screws from inside. See figures.

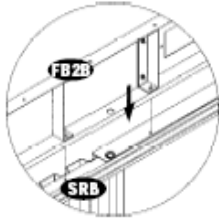

Fig.1

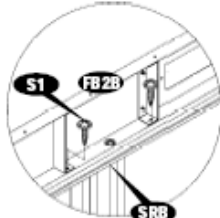
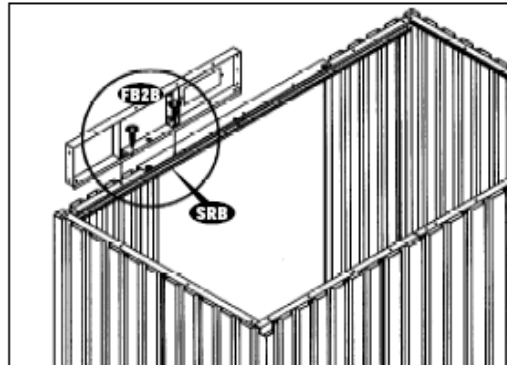

Fig.2



3. Place assembled Fascia board (FB1B) on top of the sliding channel (SLB). Align the holes with sliding channel and secure with (S1) screws from inside. See figures.

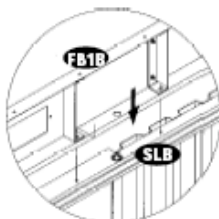

Fig.1

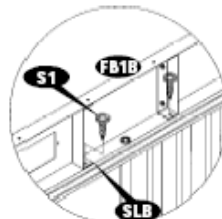
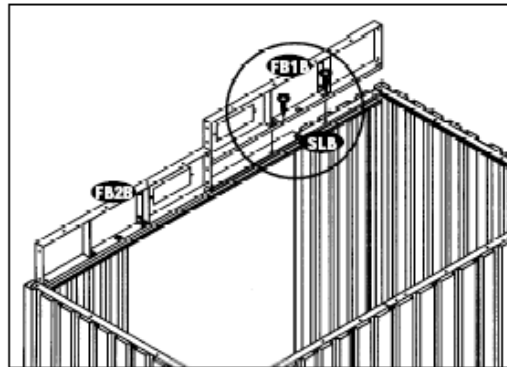

Fig.2



4. Join fascia board (FB1B & FB2B) together with fascia board support (GPSLR). Align the holes. Use (S3) bolt & nut to join the fascia boards and (S1) screws to fix to the sliding channels (SLB & SRB). See fig.

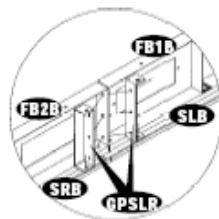

Fig.1

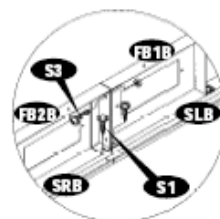
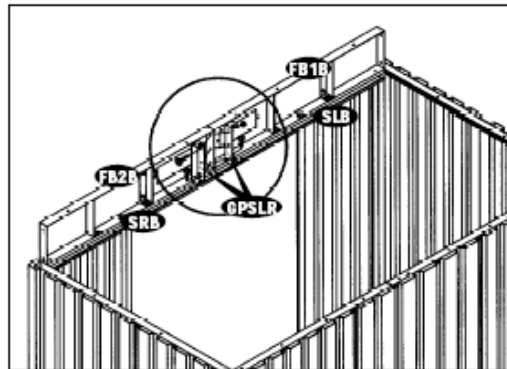
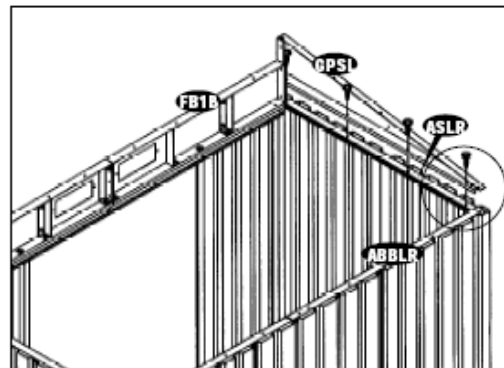
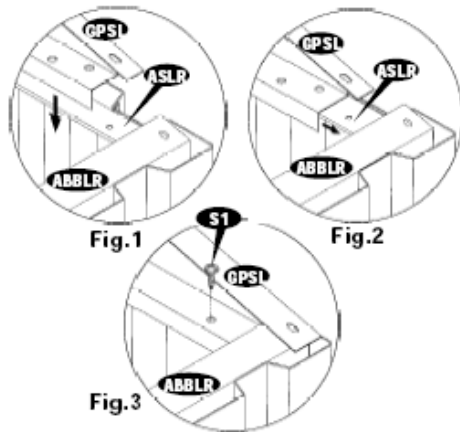

Fig.2



5. Place the Gable Panel (GPSL) on top of the top angle side (ASLR). Insert the gable panel into the top angle back (ABBLR). Align the holes with top angle and secure with (S1) screws. See figures.



6. Join fascia board (FB1B) with the gable panel (GPSL) together with fascia board support (GPSLR), secure with (S3) bolt and nuts. See figure.

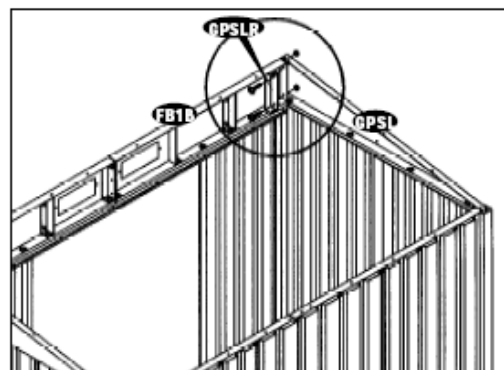
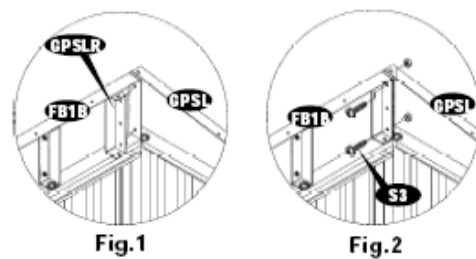

7. Place the Gable Panel (GPSR) on top of the top angle side (ASLR). Insert the gable panel into the top angle back (ABBLR). Align the holes with top angle and secure with (S1) screws. See figures.

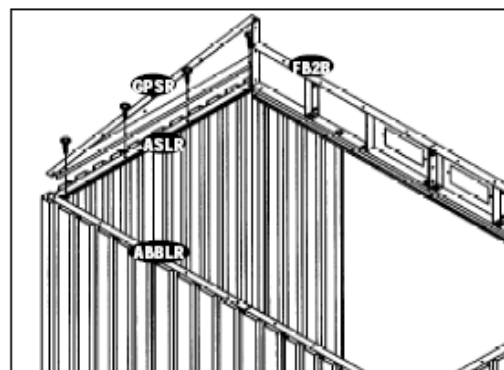

8. Join fascia board (FB2B) with the gable panel (GPSR) together with fascia board support (GPSLR), secure with (S3) bolt and nuts. See figure.

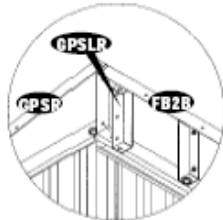

Fig.1

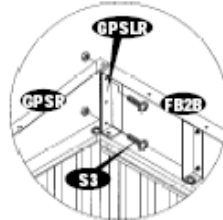
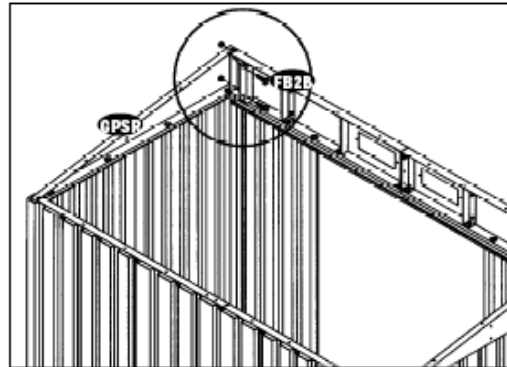
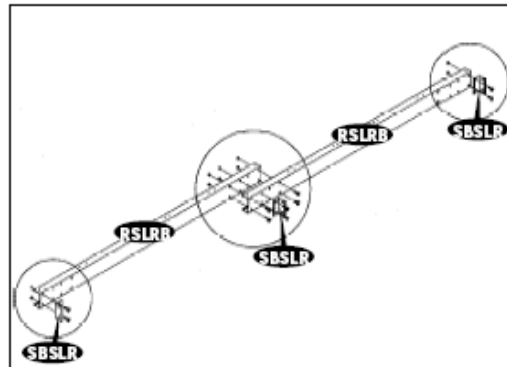
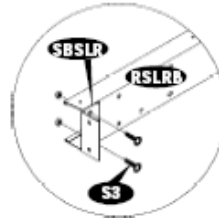
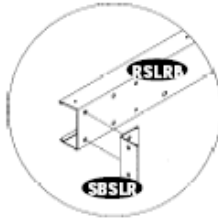
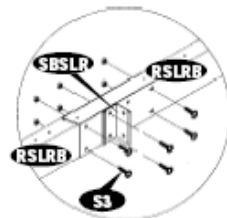
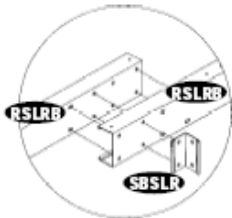

Fig.2



9. Join two roof supports (RSLRB) together with support bracket (SBSLR) at the middle. Align the holes and secure with (S3) bolt and nut. Fix (SBSLR) on both ends and secure with (S3) bolt and nut. Taper side must be positioned upward when installed. See figures.



Note *Make sure the taper side (RSLR) must be up.*

10. Fix assembled roof support (RSLRB) to the side gable panel (GPSL & GPSR). Align the holes and secure with (S3) bolt and nut with plastic washers (PW). See figure.

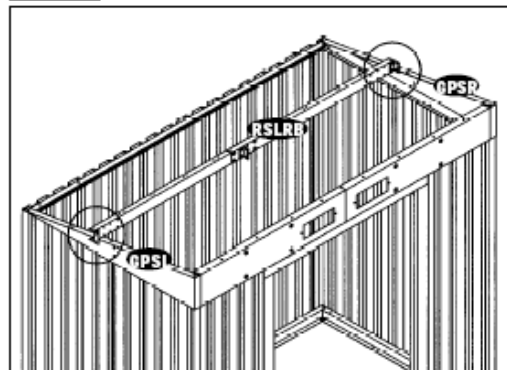
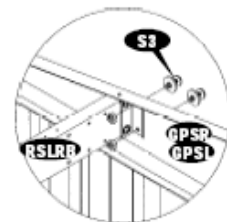

11. Fix the roof support middle (RSM) on the joined fascia board (FB1B & FB2B) in front and roof support (RSLRB) on the other side. Line up the holes and secure with (S3) bolt and nuts. See figure.

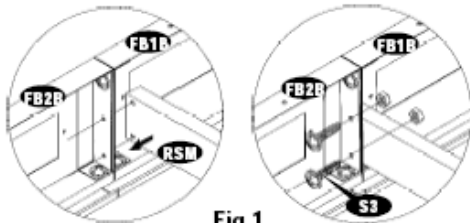

Fig.1

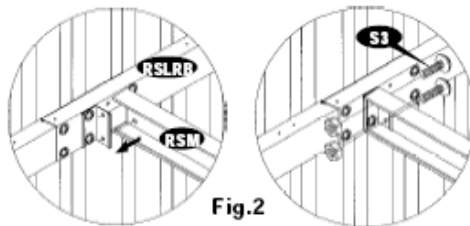
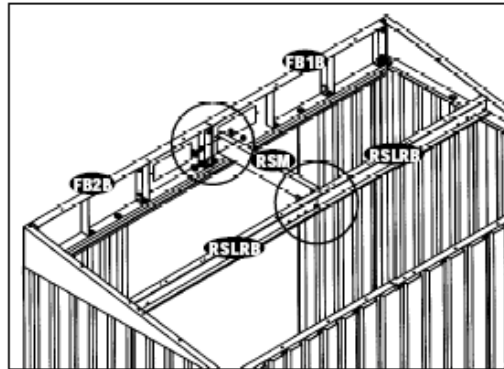
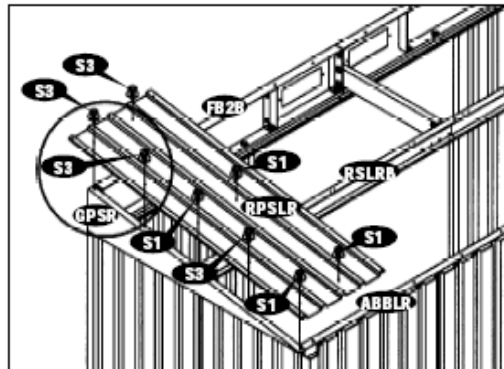
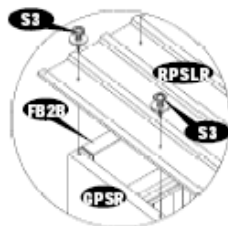

Fig.2



12. Place the roof panel (RPSLR) on top of fascia board (FB2B) and gable panel (GPSR). Line up the holes and secure with (S3) bolt and nut with washers (PW). Use (S1) screws with washers when fixing to roof support (RSLRB) and top angle (ABBLR). Line up the holes. Follow screw marks.



13. Place the roof panel (RPCLR) on the roof structure (RSLRB), top angle (ABBLR) and fascia board (FB2B). Line up all the holes and secure with (S1) screws with washers and (S3) bolt and nut with washers. Follow screw marks where ever required.



Note Make sure the overlapping position is as shown in the blown up.

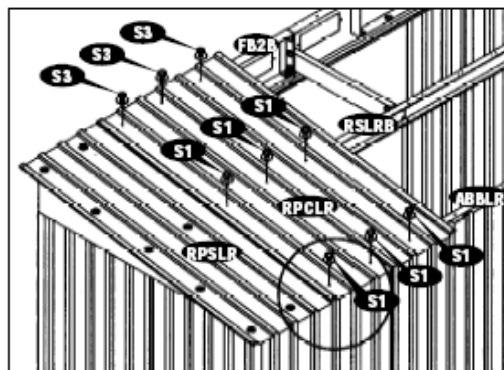
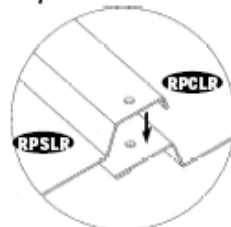

14. Place the roof panel (RPCLR) on top of fascia board (FB1B). Line up the holes and secure with (S3) bolt and nut with washers (PW). Use (S1) screws with washers when fixing to roof support (RSLRB) and top angle (ABBLR). Line up the holes.

Note *Make sure the overlapping position is as shown in the blown up.*

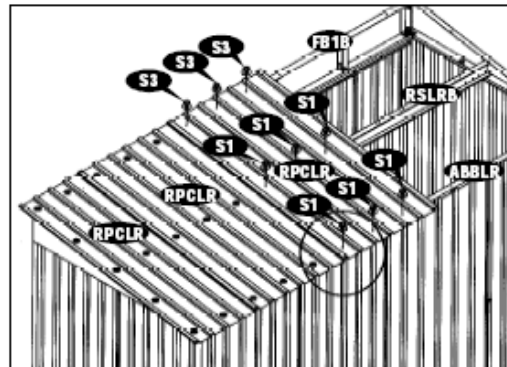
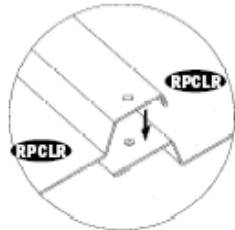

15. Place the roof panel (RPCLR) on the roof structure, top angle (ABBLR) and fascia board (FB1B). Line up all the holes and secure with (S1) screws with washers and (S3) bolt and nut with washers. Follow screw marks where ever required.

Note *Make sure the overlapping position is as shown in the blown up.*

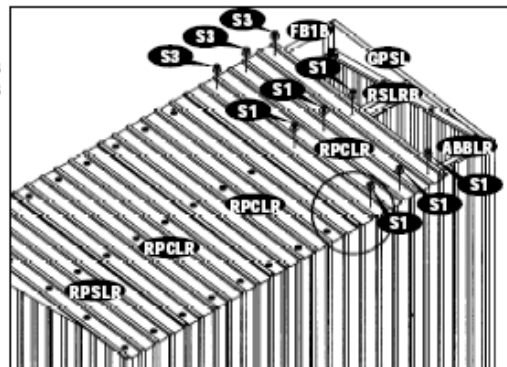
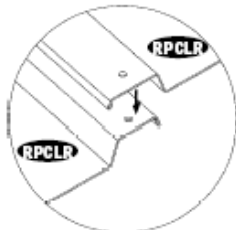

16. Place the roof panel (RPSLR) on top of fascia board (FB1B) and gable panel (GPSL). Line up the holes and secure with (S3) bolt and nut with washers (PW). Use (S1) screws with washers when fixing to roof support (RSLRB) and top angle (ABBLR). Line up the holes. Follow screw marks.

Note *Make sure the overlapping position is as shown in the blown up.*

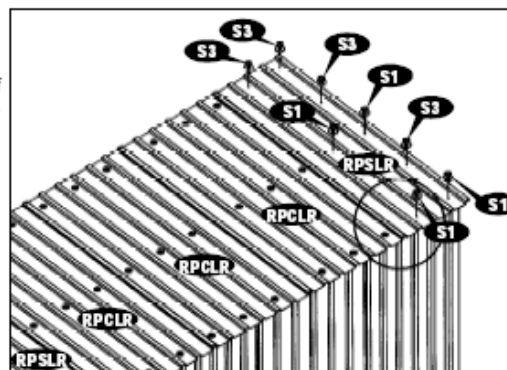
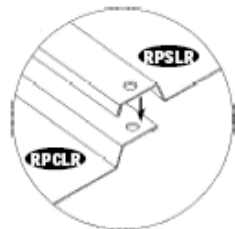

17. Assemble roof flashing (**RFSLR**) left and right with Roof panels as shown in the figure. Use (**S1**) screws with washers to secure.

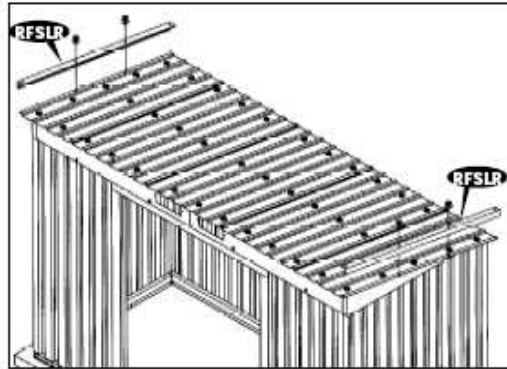

18. Assemble roof flashing (**RFLB** & **RFRB**) with roof panels as shown in the figure. Use (**S1**) screws with washers to secure.

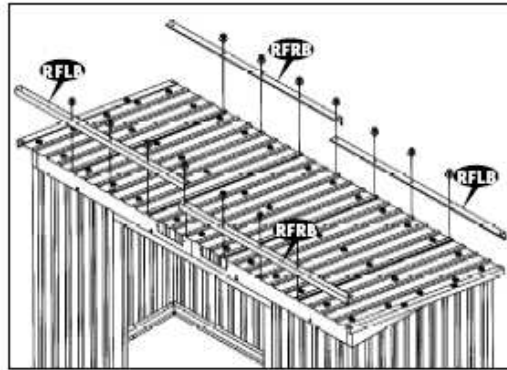

19. Place the top corners (**TC**) on the roof flashing joints and secure with (**S2**) screws with washers.

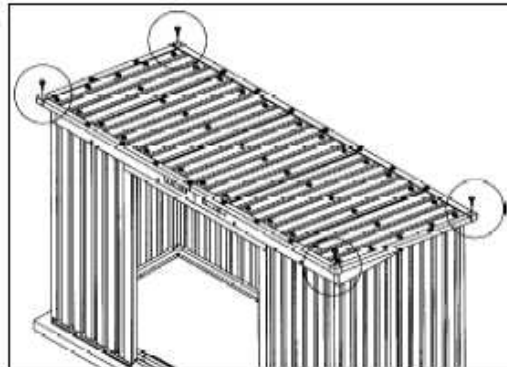
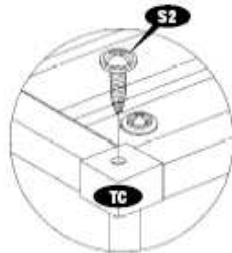

20. Insert the ventilation cover (VC) left and right into the Fascia board and secure with (S1) screws.

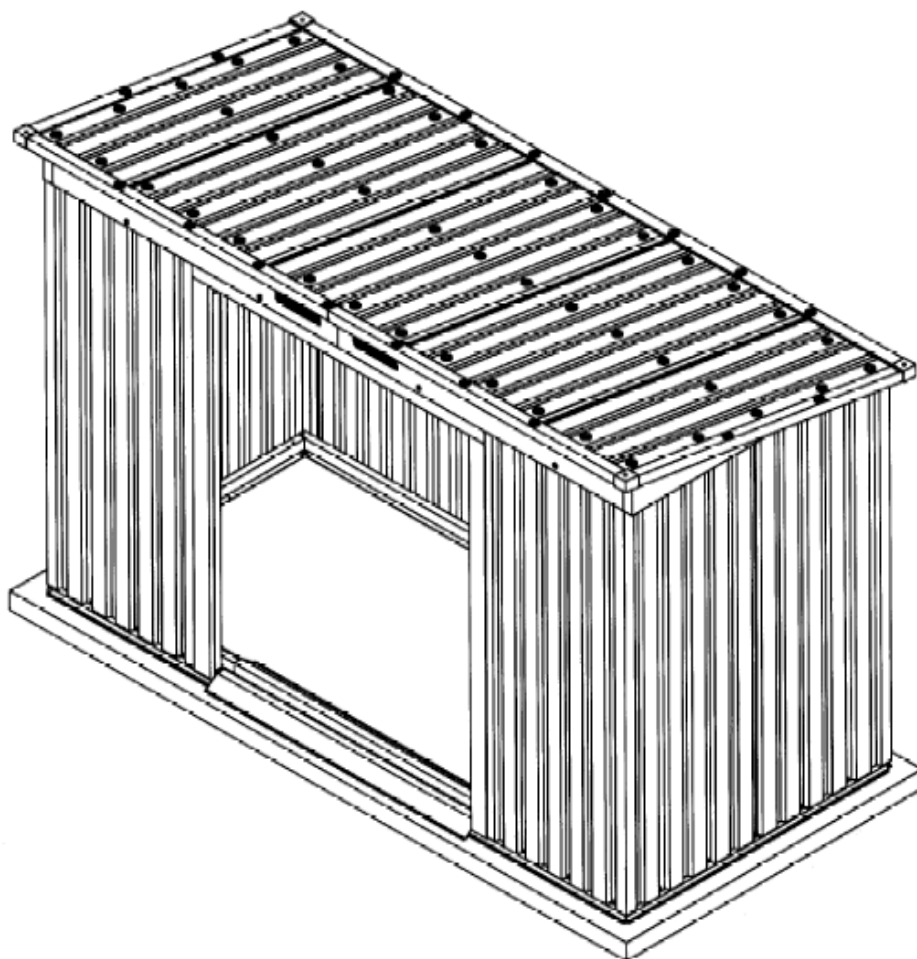
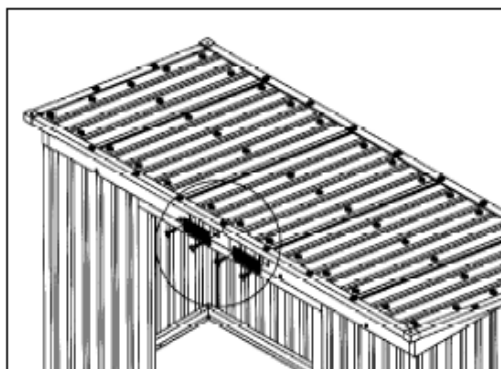
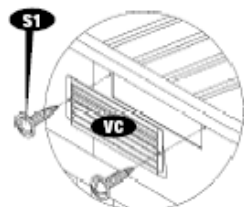

21

IMPORTANT: USE HAND GLOVES TO PREVENT INJURY.

D. Door

Parts Needed:

- | | |
|---|--------|
| (1) Door panel left | (DPLB) |
| (1) Door panel right | (DPRB) |
| (4) Door panel strip cross | (DSCB) |
| (2) Door panel strips side left and right | (DSS) |
| (1) Door panel strip top left | (TSLB) |
| (1) Door panel strip top right | (TSRB) |
| (1) Door panel strip bottom right | (BSLB) |
| (1) Door panel strip bottom left | (BSRB) |
| (2) Door handle | (DH) |
| (4) Bottom Slider | (BS) |
| (22) Plastic washer | (PW) |
| (14) Sheet metal screw | (S1) |
| (26) Machine screw | (S3) |

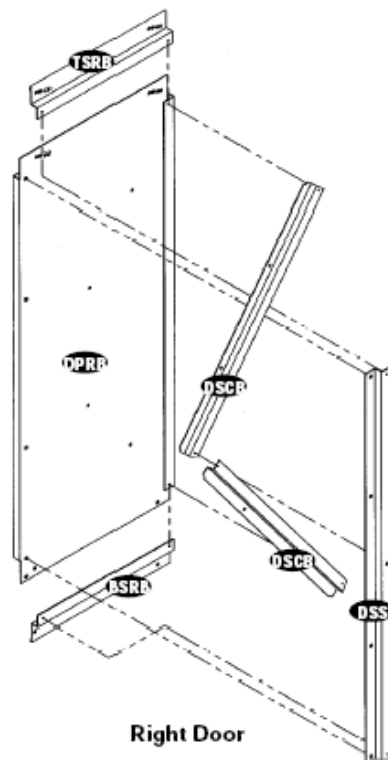
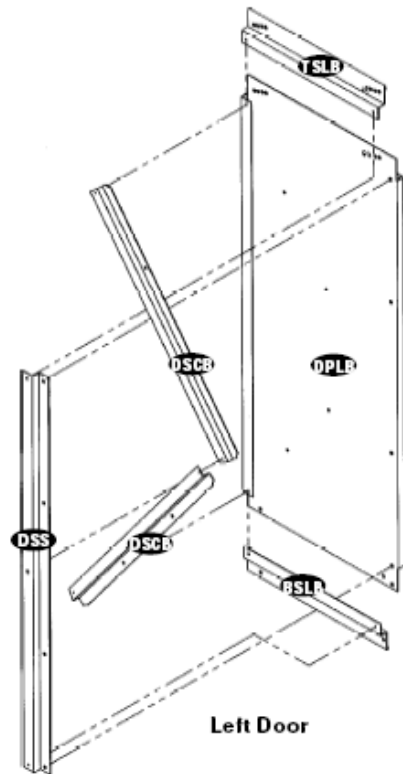

IMPORTANT: USE HAND GLOVES TO PREVENT INJURY.

Right Door Assembly

1. Assemble the door panel strip side (DSS) to the door panel right (DPRB) from inside. Use (S3) bolt and nut with washers.

Note *Remove the Polyethylene Film before assembling.*

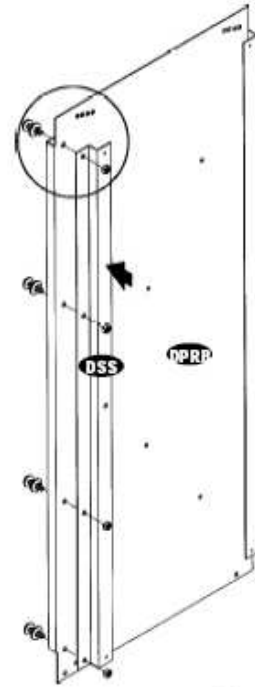
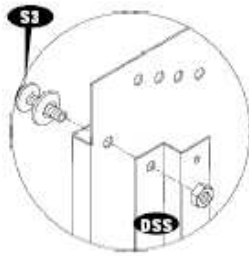

2. Assemble the door panel strip cross (DSCB) with door panel from inside. The strip one edge should go inside the (DSS) and other edge inside the door panel. Use (S3) bolt and nut with washers.

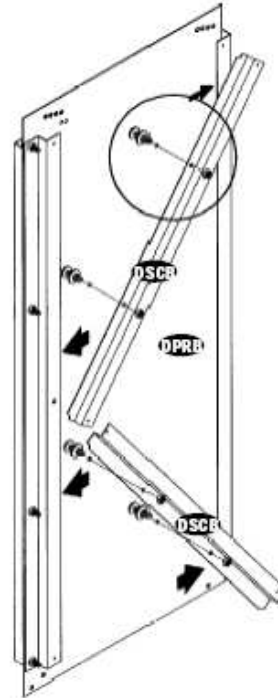
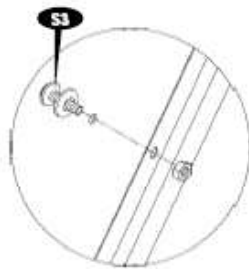

3. Secure the door panel strip cross (DSCB) to the door panel strip side (DSS) with (S1) screws. See blow up details.

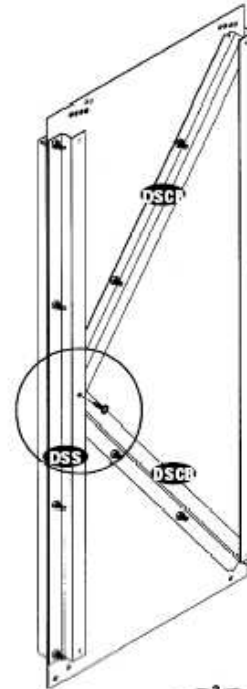
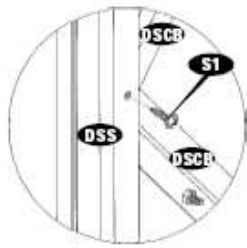

4. Assemble the door panel strip (TSRB) with door panel. Make sure the door panel top edge to be inserted into the (TSRB). See fig.1. Secure the (TSRB) to the (DSS) with (S1) screws. See fig.2. Secure the other end through the door panel to the (DSCB) with (S1) screws. See fig. 3.

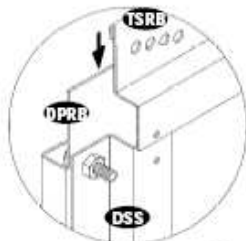

Fig.1

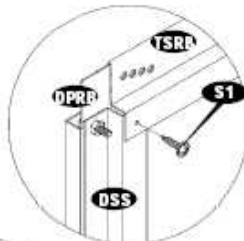

Fig.2

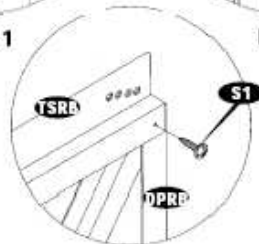
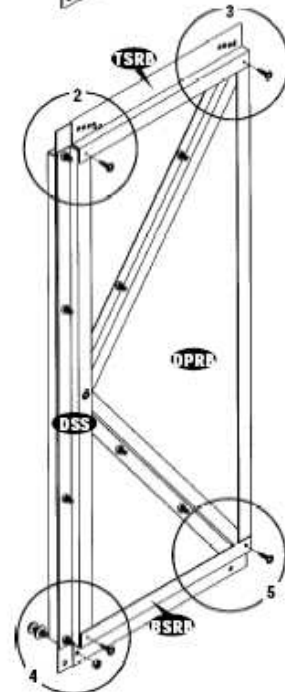

Fig.3



IMPORTANT: USE HAND GLOVES TO PREVENT INJURY.

4a. Assemble the door panel strip (BSRB) with door panel. Make sure the bottom edge of the door panel to be inserted into the (BSRB). Secure with (S1) screws to the (DSCB) and (DPRB) to the other side. See fig. 5. Use (S3) bolt and nut with washer with door panel. See fig. 4.

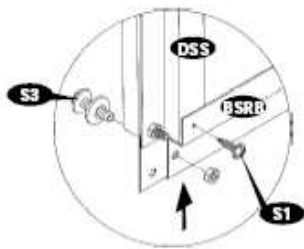

Fig.4

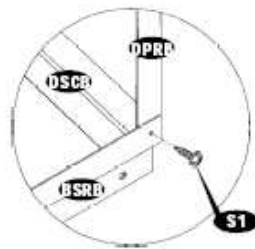
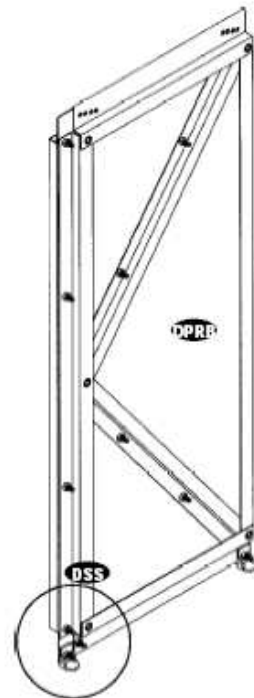
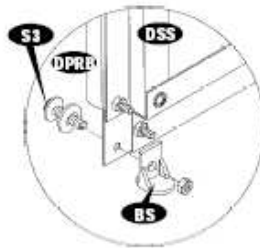
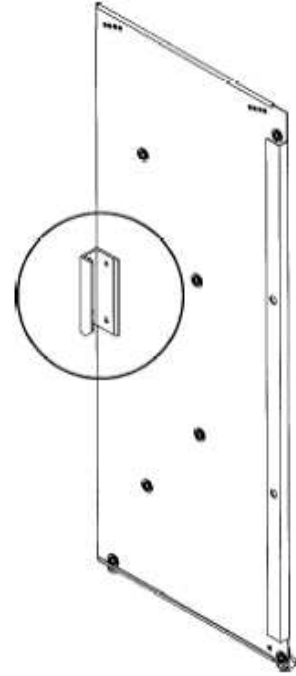
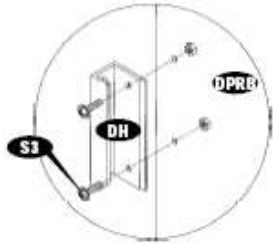

Fig.5

5. Assemble the bottom slider (BS) to the door panel bottom side at both edge with (S3) bolt and nut with washer.



6. Fix the door handle (DH) with door panel from front side with (S3) bolt and nut.



Left Door Assembly

7. Assemble the door panel strip side (DSS) to the door panel left (DPLB) from inside. Use (S3) bolt and nut with washers.



Note Remove the Polyethylene Film before assembling.

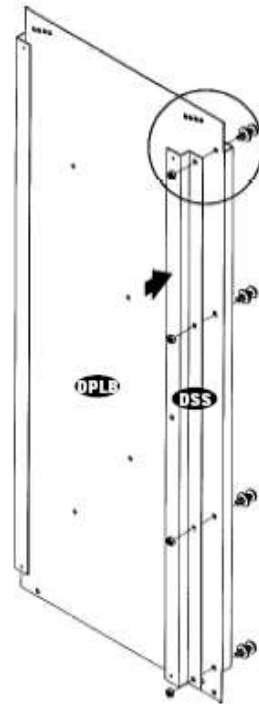
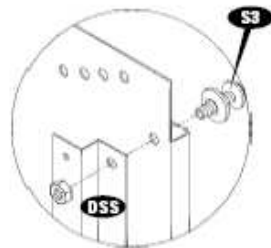

8. Assemble the door panel strip cross (DSCB) with door panel from inside. The strip one edge should go inside the (DSS) and other edge inside the door panel. Use (S3) bolt and nut with washers.

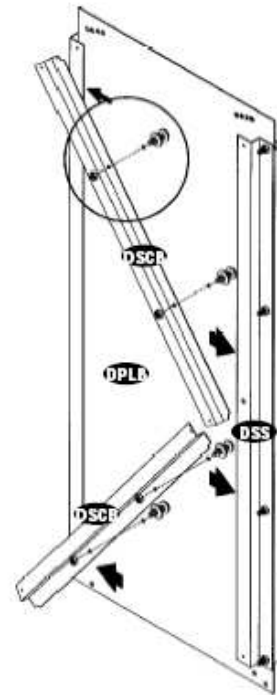
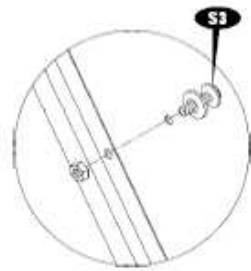

9. Secure the door panel strip cross (DSCB) to the door panel strip side (DSS) with (S1) screws. See blow up details.

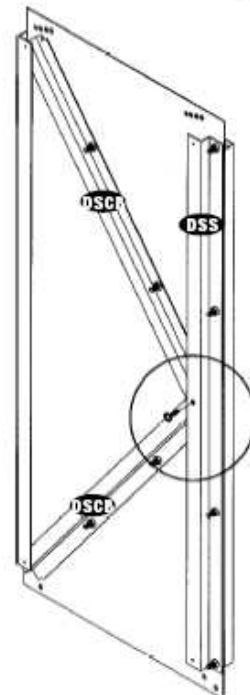
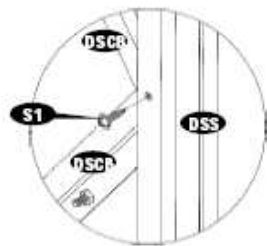

IMPORTANT: USE HAND GLOVES TO PREVENT INJURY.

10. Assemble the door panel strip (TSLB) with door pane. Make sure the door panel top edge to be inserted into the (TSLB). See fig.1. Secure the (TSLB) to the (DSS) with (S1) screws. See fig. 2. Secure the other end through the door panel to the (DSCB) with (S1) screws. See fig. 3.

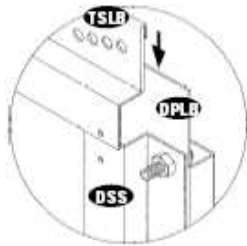

Fig.1

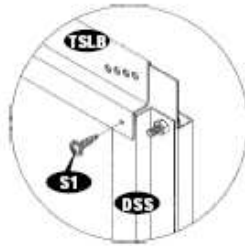

Fig.2

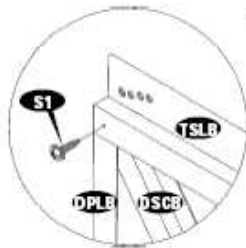
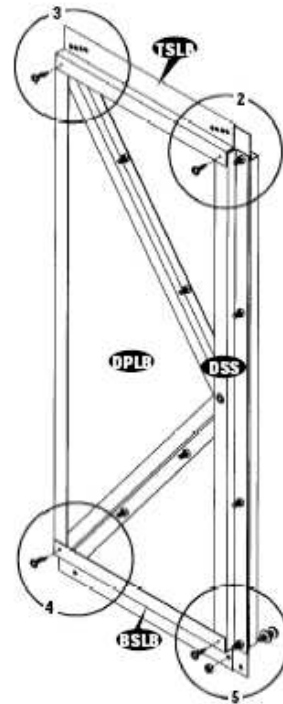

Fig.3



10a. Assemble the door panel strip (BSLB) with door panel. Make sure the bottom edge of the door panel to be inserted into the (BSLB). Secure with (S1) screws to the (DPLB) and (DSCB) to the other side. See fig. 4. Use (S3) bolt and nut with washer with door panel. See fig. 5.

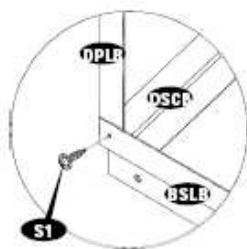

Fig.4

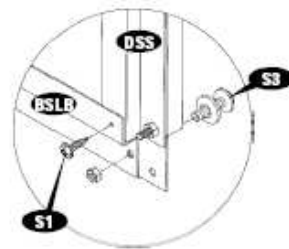
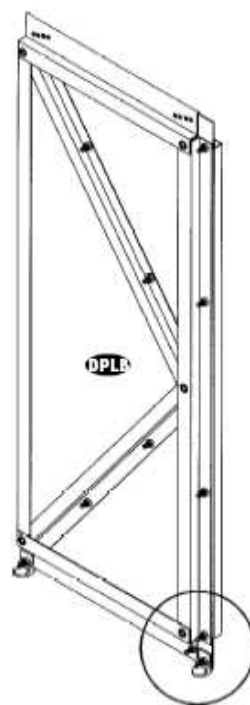
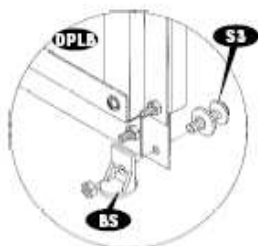
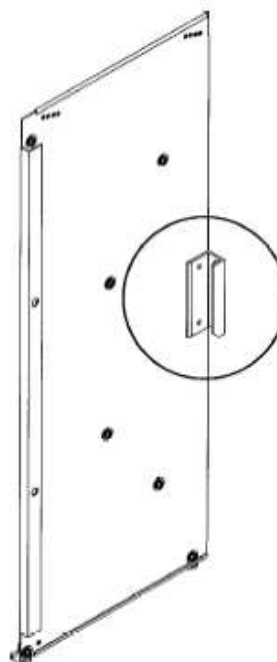
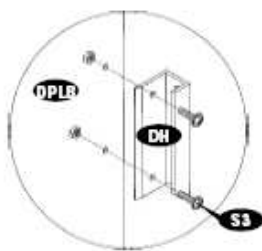

Fig.5

11. Assemble the bottom slider (BS) to the door panel bottom side at both edge with (S3) bolt and nut with washers.



12. Fix the door handle (DH) with door panel from front side with (S3) bolt and nut.



13. Slide the door panel assembly into the base bar front (BBF) & (ECB). Make sure the bottom slider (BS) should slide inside the base bar front and entrance taper channel. See fig.1. Fix the door panel top to the top slider (TS) with (S1) screws. See fig. 2 & 3.

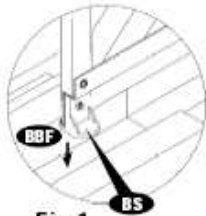

Fig.1

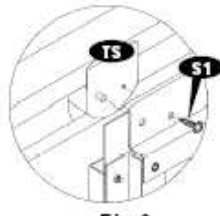

Fig.2

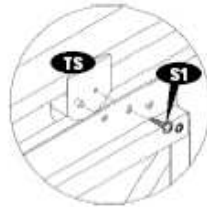

Fig.3

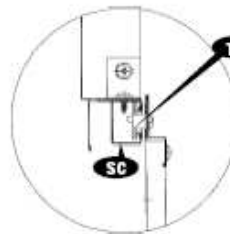
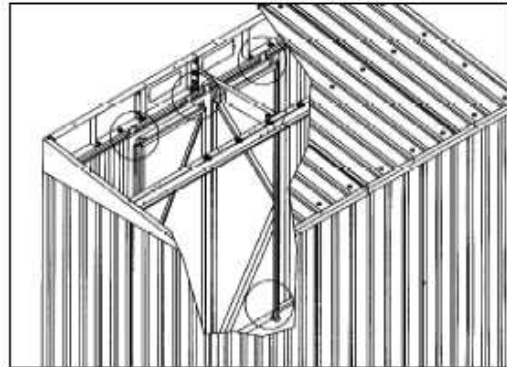

Fig.4

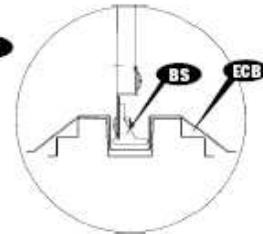
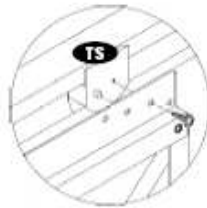

Fig.5

13a. To get proper alignment of the door realign the holes with door panel. See fig.



IMPORTANT

14. Fix the plastic screw cover (PC) to the screws and bolts edge from inside to prevent injury.

